



Datasheet Revolution iLink SL Pro Team

For more informations visit www.corratec.de



Revolution iLink SL Pro Team

Frame: Corratec Revolution iLink SL

Size: 44, 48, 52

Colors:



TECHNOLOGIES



DESCRIPTION

- 120mm suspension travel for superior riding pleasure on technically trails.
- iLink TECHNOLOGY – the rear triangle without a separate lockout achieves maximum propulsion.
- Flatter steering head angle ensures more comfort on Allmountain tours.

FRAME

CM	A	B	C	D	E	F	G	H
44	589	101	68	75	1144	435	445	610
48	616	108	68	75	1171	435	460	615
52	632	124	68	75	1192	435	475	630

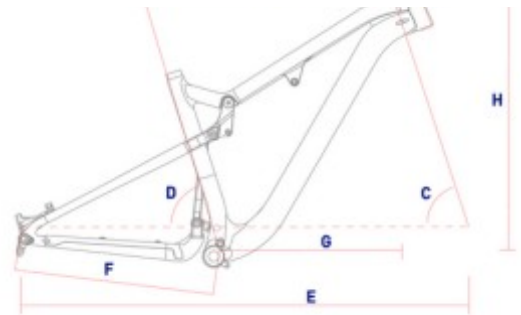

EQUIPMENT

MAIN:

FRAME:	Corratec Revolution iLink SL
FORK:	Rockshox SID Select 29" Boost
FULLY DAMPER:	Rockshox Deluxe Select
BREAKES:	SRAM DB G2 front SRAM DB G2 rear
STEM:	ZZYZX SL Alloy Stem
HANDLE BAR:	ZZYZX SLR Carbon
SADDLE:	Selle Italia Superflow Manganese
SEAT POST:	Kindshock LEV Integra

DRIVE:

CHAINWHEEL:	SRAM X1C Eagle Boost DUB
CASSETTE:	SRAM XG1295 Eagle
REAR DERAILLEUR:	SRAM X01 Eagle
SHIFT LEVERS:	SRAM GX Eagle

WHEELSET:

RIM:	DT Swiss XM1700 Spline
TIRE:	Schwalbe Racing Ray front Schwalbe Racing Ralph rear

SPECIAL:

CHAINWHEEL RATIO:	1s; 32
CASSETTE RATIO:	12S; 10 12 14 16 18 21 24 28 32 36 42 52
FORK SUSPENSION TRAVEL:	120 mm
SIZE BRAKE DISC:	180 mm front 160 mm rear

Because of the problems in the delivery chain arising from the current COVID-19 situation, the bike can be delivered with modifications.

Rendering is for Reference only.